

# HALUX N30-1 P SG

## TECHNICAL DATA

FITTED WITH	1 x LED module
LUMINOUS POWER	30 000 lux / 0.5 m *
ILLUMINANCE FIELD 0.5 m	Ø 18 cm (7.1 in.) *
COLOR RENDERING INDEX	CRI > 93
COLOR TEMPERATURE	4 400 K*
OPERATION EQUIPMENT	Electronic converter
VOLTAGE	100-240 V; 50/60 Hz
CORD LENGTH	1.7 m (5.6 ft.)
LUMINAIRE BODY	Polycarbonate (PC) & acrylonitrile butadiene styrene copolymer (ABS)
WEIGHT (NET)	1.6 kg (3.5 lbs.)
POWER CONSUMPTION	8 W
USAGE	Push button on light head
BALANCE OF ARTICULATION JOINTS	Friction
CLASS OF PROTECTION	II
PROTECTION RATING	IP 20
STANDARDS MET	EN 60601-1, EN 60601-2-41
SPECIAL FEATURES	Continuously dimmable, maintenance-free, joint at the foot
MOUNTING	Mounting pin (Ø 16 mm)
ACCESSORIES	Rolling floor stand, rail mounting with removal guard, table clamp with removal guard, universal mount with removal guard, extension arm with removal guard, wall mount with removal guard

## EXAMINATION LIGHTS



N30-1 P SGV



N30-1 P SGH

	connection horizontal	connection vertical	dimmable	Order No.
<b>HALUX N30-1 P SGV</b>		<b>x</b>	<b>x</b>	D15.992.000-00806675 - pure white - EU, UK, US, AUS
<b>HALUX N30-1 P SGH</b>	<b>x</b>		<b>x</b>	D15.993.000-00806676 - pure white - EU, UK, US, AUS

## LIGHT DISTRIBUTION

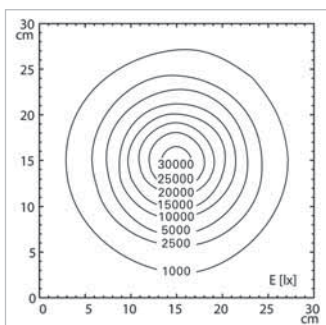
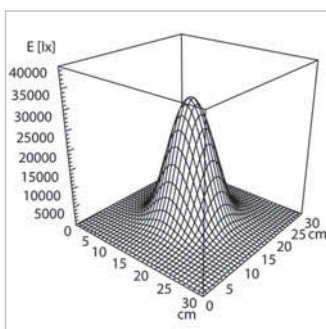

## TECHNICAL DRAWING

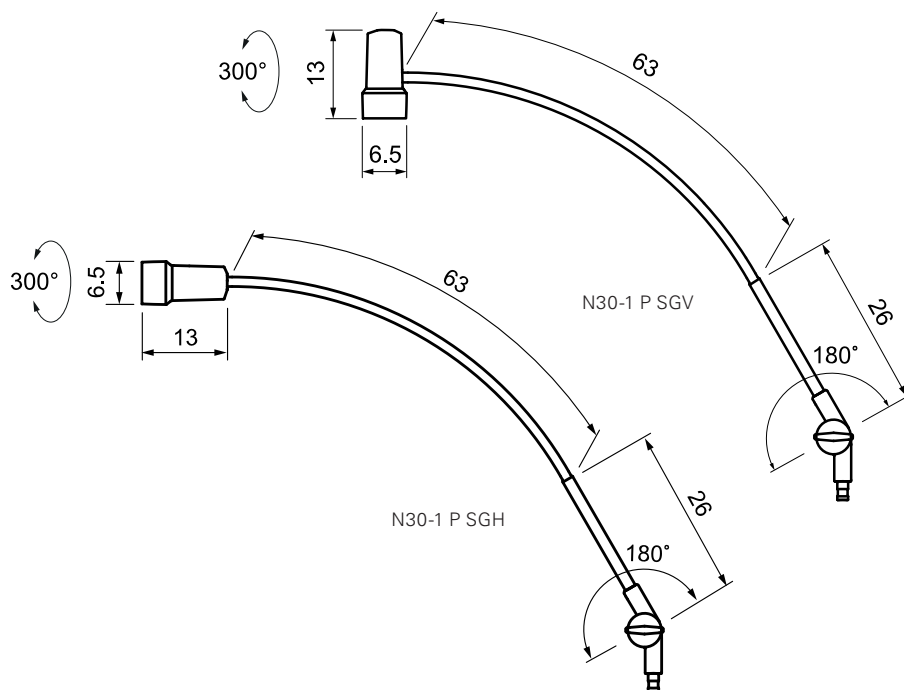

measurements in centimeters

\* -10% / +20% tolerance